

步进电机尺寸图/STEP MOTOR DIMENSIONS

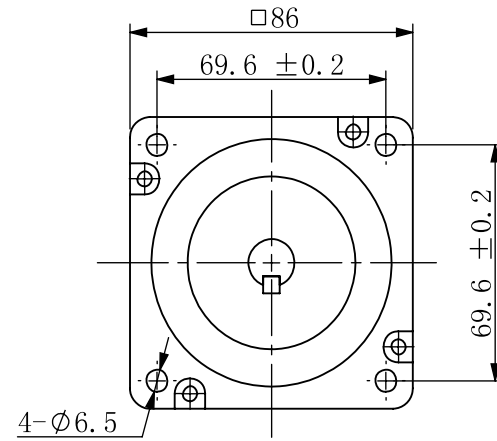
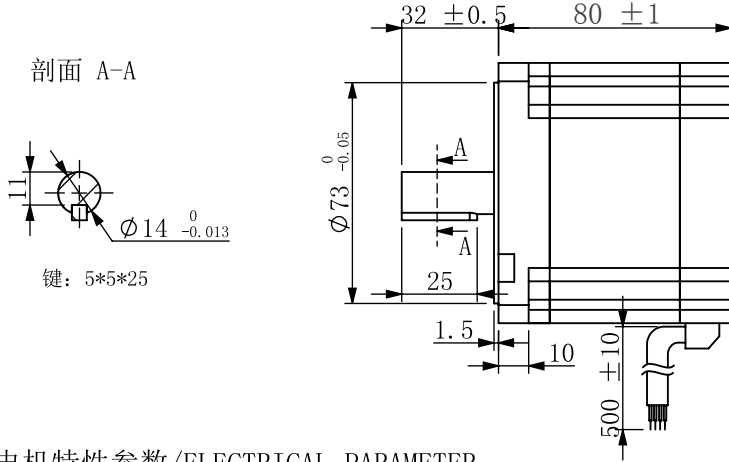

电机特性参数/ELECTRICAL PARAMETER

| | |
|---|--|
| 步距角/STEP ANGLE | 1.8° ± 5% |
| 相数/NO. OF PHASES | 2 |
| 额定电压/RATED VOLTAGE | 2.46V |
| 额定电流/RATED CURRENT | 6.0A |
| 电阻/RESISTANCE | 0.41ohm ± 10% AT 25°C |
| 电感/INDUCTANCE | 2.82mH ± 20% AT 1kHz, 1Vrms |
| 保持力矩/HOLDING TORQUE | 4.5N.m |
| 运行力矩/(AT —PPS) RUNNING TORQUE(AT —PPS) | ——以上/MIN (——V.DC, ——A/相(PHASE), ——相励磁/EX) |
| 绝缘耐压/DIELECTRIC STRENGTH | 500V A.C 1分钟/MINUTE |
| 绝缘电阻/INSULATION RESISTANCE | 100MΩ 以上/MIN. |
| 绝缘等级/INSULATION CLASS | CLASS B |
| 温度上升/TEMPERATURE RISE | 80K MAX. |
| 转子惯量/ROTOR INERTIA | 1400g.cm ² |
| 重量/WEIGHT | 约/APPROX. 2250克/g |
| 允许轴向负载/ALLOWABLE THRUST LOAD | 10N |
| 允许径向负载/ALLOWABLE RADIAL LOAD | 100N(轴端/ON THE SHAFT END) |
| 运行环境温度/OPERATION AMBIENT TEMP. | -20°C —— +50°C |
| 运行环境湿度/OPERATION AMBIENT HUM. | 15% —— 90% |
| 寿命/LIFE | 5000小时/HOURS |

备注(NOTE):

- 额定电流, 两相同时通电/AT RATED CURRENT, TWO PHASES ON.
- 热阻法: 电机安装在84*84*T5的铝板上, 电机线圈两端通额定电压, OPPS /MEASURED BY RESISTANCE METHOD. MOUNT WITH ALUMINUM HEAT SINK 84*84*T5 AT TWO WINDING BE EXCITED BY RATED VOLTAGE, OPPS, 2PHASE ON.
- 寿命测试条件: 整步, 运行速度为500PPS, 轴承的表面温度不超过70° C LIFE TEST CONDITION: 2PHASE EXCITING, FULL STEP, AT 500PPS. STARTING PULSE, BEARING TEMPERATURE SHOULD BE 70° C MAX.

励磁顺序(2相励磁) VS. 旋转方向 EXCITING SEQUENCE (TWO PHASES) VS. DIRECTION OF ROTATION

| | | | | | |
|-----|------|----|----|----|----|
| | STEP | A+ | B+ | A- | B- |
| CW | 1 | + | + | - | - |
| | 2 | - | + | + | - |
| | 3 | - | - | + | + |
| | 4 | + | - | - | + |
| | | | | | |
| CCW | | | | | |

从安装面看为顺时针方向
CLOCKWISE VIEW FROM MOUNTING SIDE

接线图/WIRING DIAGRAM

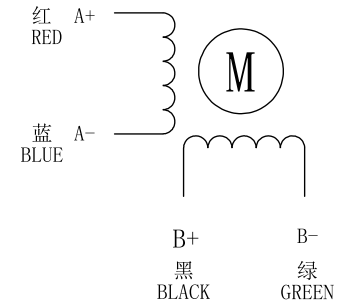

| | | | | | | | | | |
|--|----------|-------------|-------------|-----------------|-------------------|----------|------------|----------------------------------|---|
| CONFIRMED&ACCEPTED BY COTUMER (客户确认&接受) | | | | | | | | | |
| COMPANY CHOP&SIGNATURE (盖章&签名) | | | | | | | | | |
| 一般公差 TOLERANCE | ±0.3/±3° | 版本 REV. | 年月日 DATE | 变更番号 ECR NO. | 变更内容 REVISIONS | 设计 BY | 备注 NOTE | REV. | A |
| 设计/DESIGNED | | 比例 SCALE | | 型号/MODEL | | | | 三维图 THIRD ANGLE PROJECTION | |
| 审核/CHECKED | | 单位 UNIT | mm | 86B80 | | | | | |
| 骁鸣智能科技(广州)有限公司 | | | | | | | 页 SHEET | 1/1 | |