

永磁直流伺服电动机规格书

PERMANENT MAGNET DC SERVO MOTOR SPECIFICATION

版本 REV	变更号 ECN NO	变更内容 CONTENT CHANGED	处数 NO.	日期 DATE	设计 DESIGN

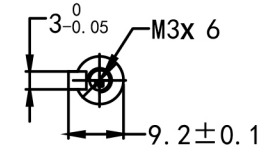
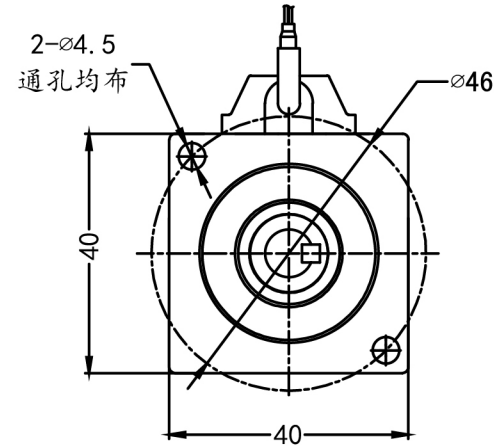
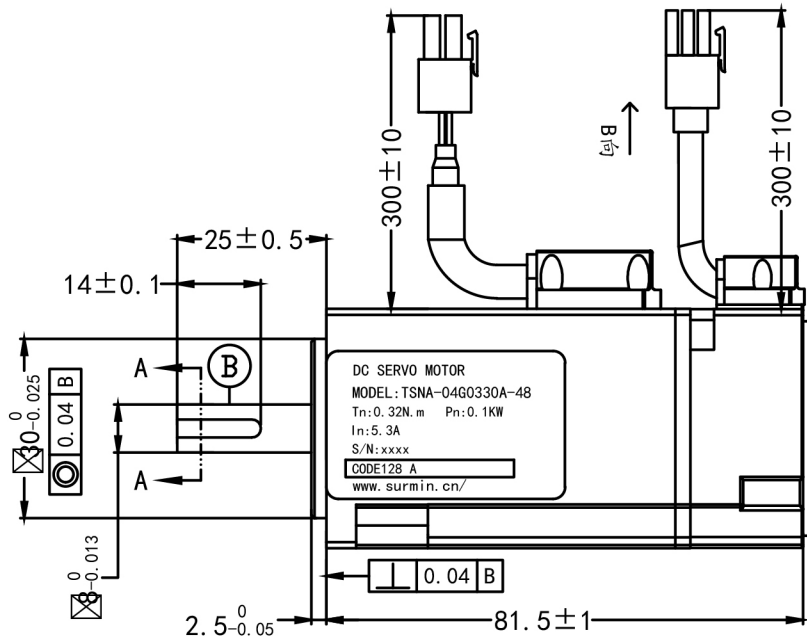

SECTION A-A

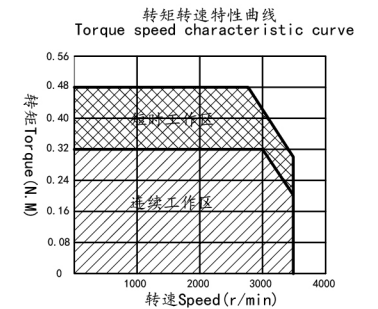

使用说明:

Instructions

使用环境温度-20--40° C不结冰
Operating ambient temperature -20--40 ° C no ice
使用环境湿度20%--80%RH不结露
Operating environment humidity 20%--80%rh no condensation
1000m以下使用, 1000m以上请降额使用, 具体参照海拔降额曲线

For use below 1000m, please reduce the rating for use above 1000m. Refer to the altitude derating curve for details

电源线端子拉脱力 $\leq 58N$
Pull off force of power line terminal is less than or equal to 58N

编码器线端子拉脱力 $\leq 13N$
Pull off force of encoder line terminal is less than or equal to 13 N

参数列表

parameters List

额定电压 Rated Voltage (V)	48	线电阻 Line-Line Resistance (Ω)	1.12±10% (20°C)
额定功率 Rated Power (W)	100	线电感 Line-Line Inductance (mH)	1.06±20% (20°C)
额定电流 Rated Current (A)	5.3	转动惯量 Rotor inertia ($\times 10^{-4} \text{kg/m}^2$)	0.079
峰值电流 Peak Current (A)	7.9	绝缘等级 Insulation Class	F
额定转速 Rated Speed (rpm)	3000	绝缘电阻 Insulation resistance	DC500V $\geq 10M\Omega$
最高转速 Peak Speed (rpm)	3500	防护等级 Protection class	IP65
额定转矩 Rated Torque (N.M)	0.32	允许最大径向负载 Maximum allowable radial load (N)	68
峰值扭矩 Peak Torque (N.M)	0.48	允许最大轴向负载 Maximum allowable axial load (N)	44
反电势 Voltage Constant (V/Krpm)	4.7	重量 Weight (kg)	0.46
力矩系数 Torque Coefficient (N.M/A)	0.06		

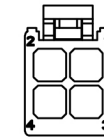

B向视图

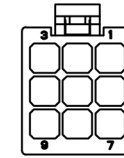

塑壳: AMP172167-1
端子: 170360-1

塑壳: AMP172169-1
端子: 170359-1

17位多圈磁编接线顺序 17-bit multi-turn magnetic encoder wiring sequence								电机绕组接线顺序 Motor winding wiring sequence				
序号 Serial number	1	2	3	4	5	6	7	序号 Serial number	1	2	3	4
颜色 Color	屏蔽	红 Red	白 White	黄 Yellow	绿 Green	蓝 Blue	黑 Black	颜色 Color	红 Red	白 White	黑 Black	黄绿 Yellow/Green
定义 Definition	PE	VCC	GND	SD+	SD-	BAT+	BAT-	定义 Definition	U	V	W	PE
CTQ SIGN: \triangle Customer \triangle Process \triangle Law 材料符合ROHS要求 All Material Are To Be Rohs Compliant								骁鸣智能科技(广州)有限公司				
NAMES	SIGNATURE	DATE	Unspecified tolerance		视角 FIRST ANGLE METHOD	比例 SCALE	单位 UNIT	变更标识 ECN SIGN	名称 TITLE	TSNA-04G0330A-48		
设计 DESIGN		2022 7.6	常规公差: Tolerances 角度 Angles $\pm 0.1^\circ$ 倒角 Chamfer ± 0.3		\oplus	1:1	mm	*	图号 DWG. NO	/		
标准化 STANDARD			Unit: mm GB/T1804-M ISO2768-1 ClassM		件号 PART NUMBER	1	版本 REV	A	表单编号 Form Code			
审核 CHECK												