

闭环步进电机尺寸图/CLOSED LOOP STEPPER MOTOR

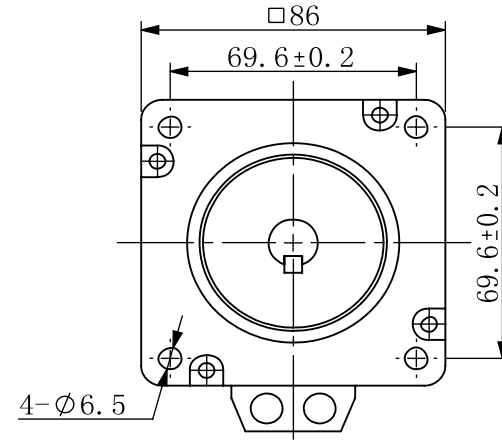
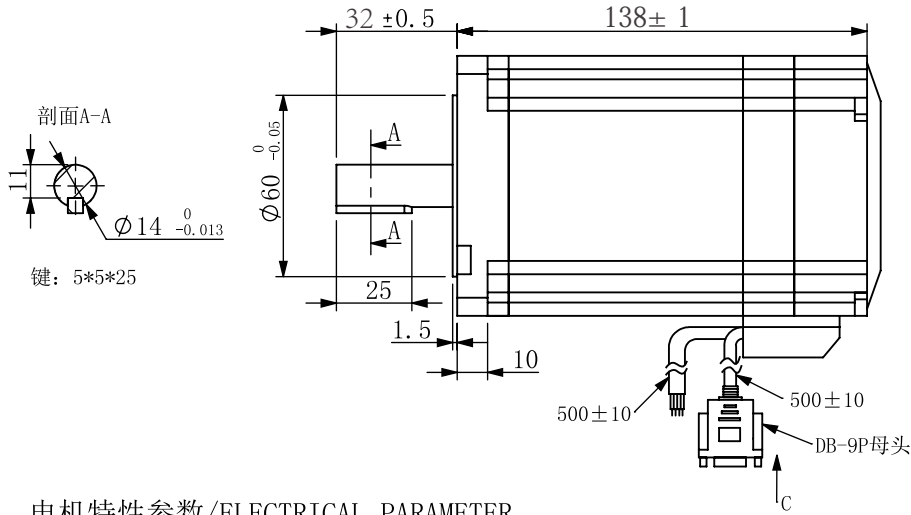

电机特性参数/ELECTRICAL PARAMETER

步距角/STEP ANGLE	1.8° ± 5%
相数/NO. OF PHASES	2
额定电压/RATED VOLTAGE	3.18V
额定电流/RATED CURRENT	6.0A
电阻/RESISTANCE	0.53ohm ± 10% AT 25°C
电感/INDUCTANCE	5.54mH ± 20% AT 1kHz, 1Vrms
保持力矩/HOLDING TORQUE	8.5N.m
运行力矩/(AT —PPS) RUNNING TORQUE(AT —PPS)	——以上/MIN (——V.DC, ——A/相(PHASE), ——相励磁/EX)
绝缘耐压/DIELECTRIC STRENGTH	500V A.C 1分钟/MINUTE
绝缘电阻/INSULATION RESISTANCE	100MΩ 以上/MIN.
绝缘等级/INSULATION CLASS	CLASS B
温度上升/TEMPERATURE RISE	80K MAX.
转子惯量/ROTOR INERTIA	2800g.cm ²
重量/WEIGHT	约/APPROX. 3900克/g
允许轴向负载/ALLOWABLE THRUST LOAD	10N
允许径向负载/ALLOWABLE RADIAL LOAD	100N(轴端/ON THE SHAFT END)
运行环境温度/OPERATION AMBIENT TEMP.	-20°C——+50°C
运行环境湿度/OPERATION AMBIENT HUM.	15%——90%
寿命/LIFE	5000小时/HOURS

励磁顺序(2相励磁)VS. 旋转方向
EXCITING SEQUENCE(TWO PHASES)
VS. DIRECTION OF ROTATION

	STEP	A+	B+	A-	B-
CW	1	+	+	-	-
	2	-	+	+	-
	3	-	-	+	+
	4	+	-	-	+
CCW					

从安装面看为顺时针方向
CLOCKWISE VIEW FROM MOUNTING SIDE

接线图/WIRING DIAGRAM

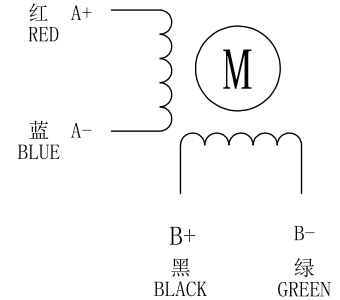

备注(NOTE):

- 额定电流, 两相同时通电/AT RATED CURRENT, TWO PHASES ON.
- 热阻法: 电机安装在84*84*T5的铝板上, 电机线圈两端通额定电压, OPPS /MEASURED BY RESISTANCE METHOD. MOUNT WITH ALUMINUM HEAT SINK 84*84*T5 AT TWO WINDING BE EXCITED BY RATED VOLTAGE, OPPS, 2PHASE ON.
- 寿命测试条件: 整步, 运行速度为500PPS, 轴承的表面温度不超过70°C LIFE TEST CONDITION: 2PHASE EXCITING, FULL STEP, AT 500PPS. STARTING PULSE, BEARING TEMPERATURE SHOULD BE 70°C MAX.

CONFIRMED&ACCEPTED BY COTUMER (客户确认&接受)									
COMPANY CHOP&SIGNATURE (盖章&签名)									
一般公差 TOLERANCE	±0.3/±3°	版本 REV.	年月日 DATE	变更番号 ECR NO.	变更内容 REVISIONS	设计 BY	备注 NOTE	REV.	A
设计/DESIGNED		比例 SCALE		型号/MODEL					三维图 THIRD ANGLE PROJECTION
审核/CHECKED		单位 UNIT	mm	86B118EC					
骁鸣智能科技(广州)有限公司							页 SHEET	1/1	